

176

**The VW  
Commercial.**

**The VW  
Microbus.**

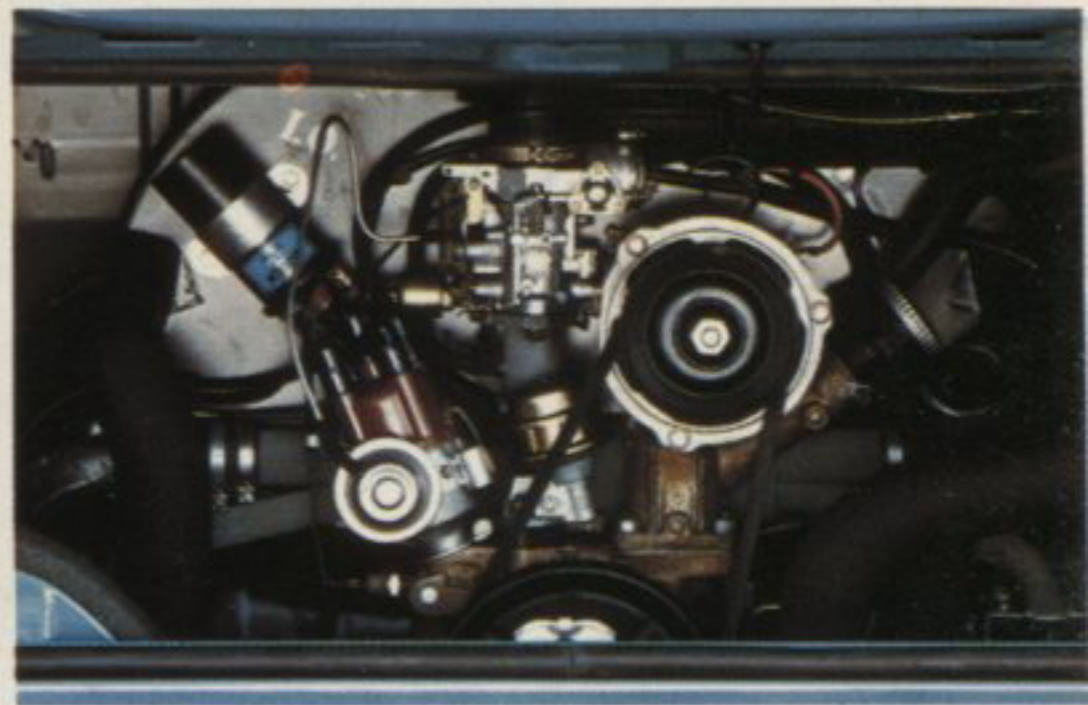



## The VW Commercial. The

The VW Commercial has nothing new to offer. Which is precisely what makes it so remarkable.

The way it stands, it has been tested, selected, driven and found acceptable over 4 million times to date.

Sure – in all the years it has been around, it was worked on and improved on, again and again. But it was the same basic idea which was

behind its success in the past 25 years. Which shows that we were right in sticking to it.

The basic idea which made the VW Commercial one of the classic successes of automobile history is simple. Like many great ideas. We said to ourselves: the best way to exploit an area is with a cuboid, and the fastest version of a cuboid is a cuboid on wheels.

And to this day the VW Commercial has re-

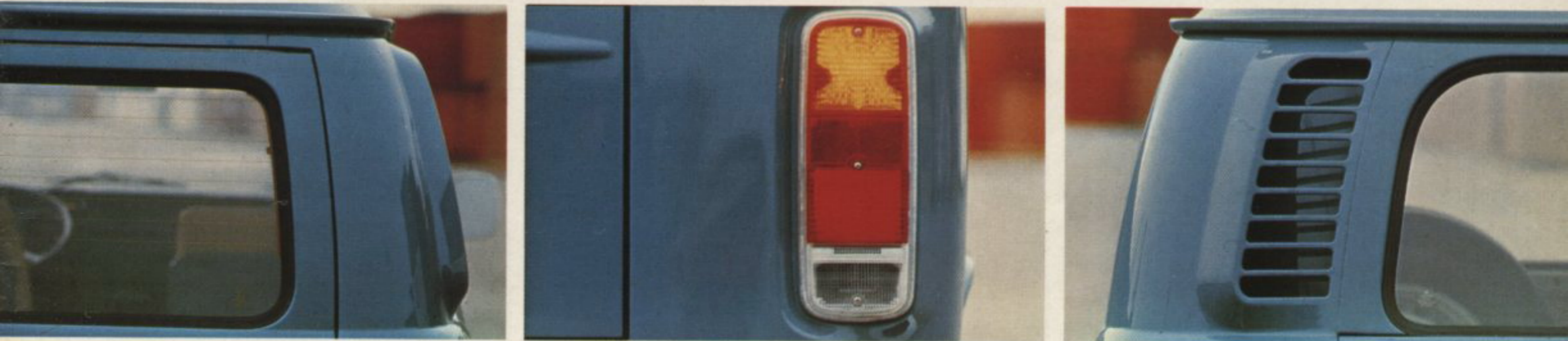

## world's most hard-working car.

remained a cuboid on wheels – of course in a great variety of different versions. For all its 25 years, it still continues to be an outstanding example of modern compact design.

The VW Commercial is like a crate. Which is only logical since it is made to take large transports. So, it is wide, roomy, and easily accessible. Tough, handy and compact. It has clean, functional lines, without frills or clutter to obstruct

the view. Every square inch is optimally accessible and available for loads.

The VW Commercial comes with the choice of 2 engines and is available in 8 different versions. Its unique versatility, its indefatigability and its proverbial reliability have advanced it to the top transport vehicle in its class. Nothing succeeds like success.

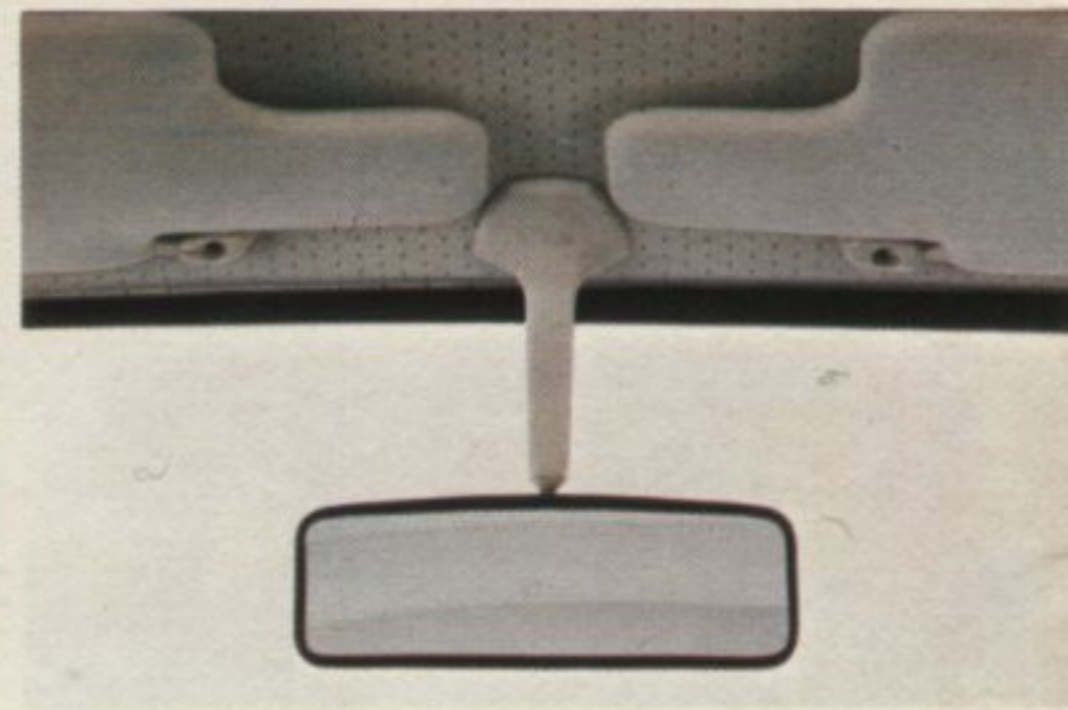
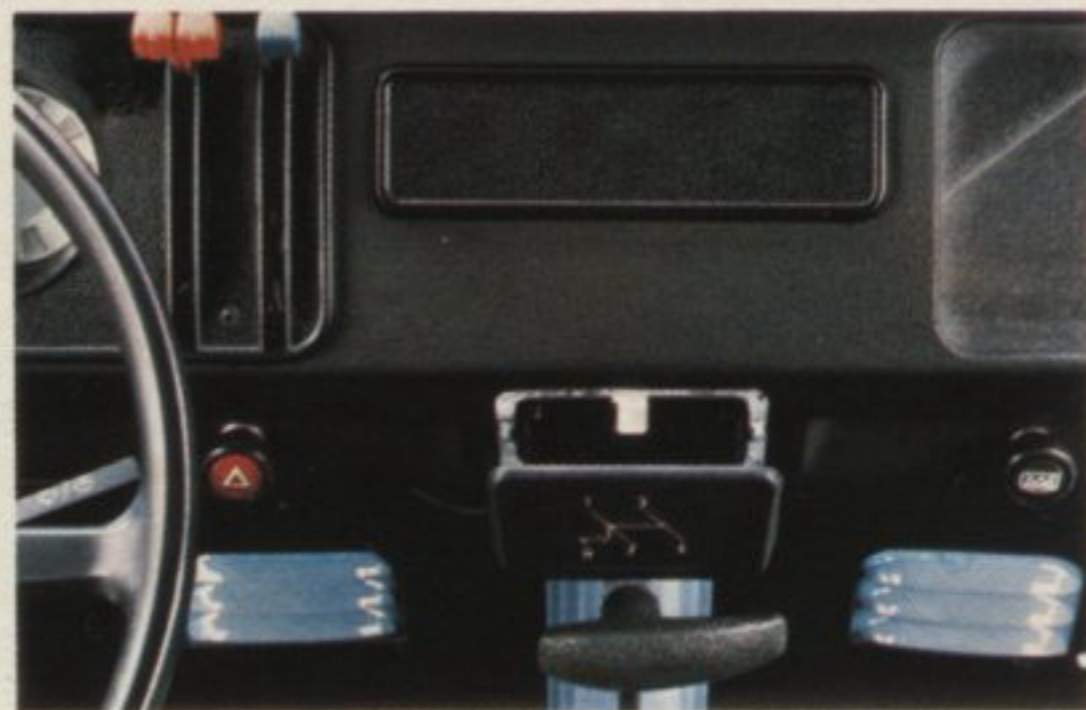
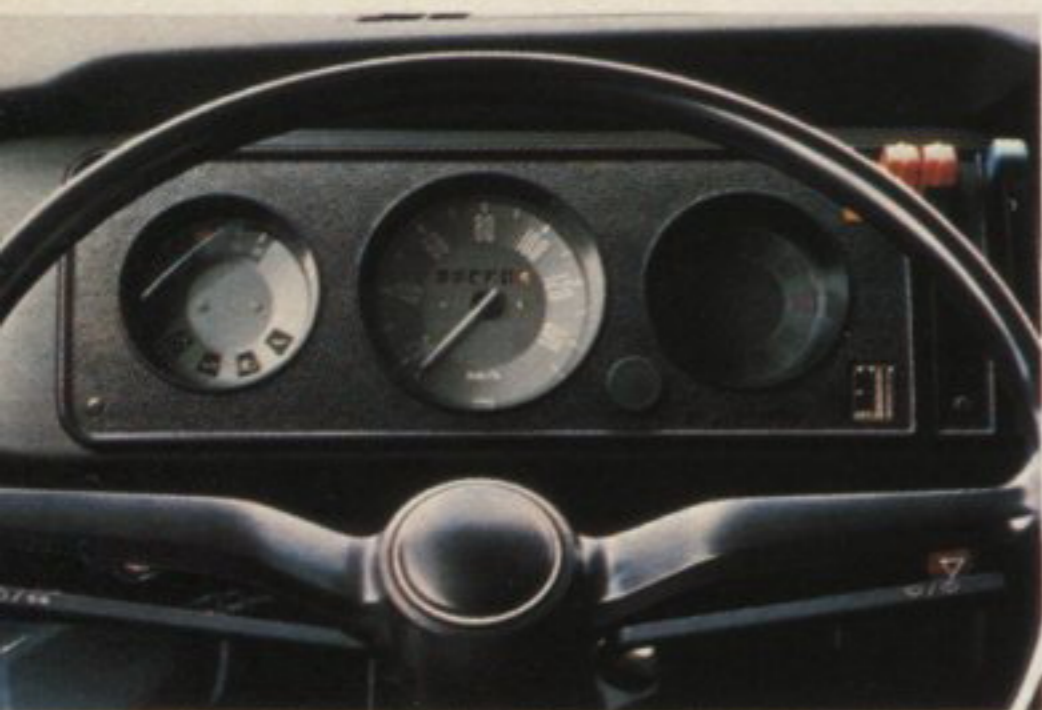

## The VW Commercial.

If comfort is one of the qualities you are looking for in a commercial, then you have come to the right place.

Its spacious driver's cab is anything but Spartan. The driver's seat is individually adjustable. The cab is fully lined to the ceiling, providing insulation against both heat and noise.

Fast and efficient heating and ventilation systems keep the atmosphere pleasant at all

times. There are defroster vents to clear fogged windscreen and side windows. The windscreen has been drawn well up into the roof for better visibility.

Furthermore, the VW Commercial has a safety chassis: individual wheel suspension, and even a semi-trailing arm rear axle, which is usually reserved to the more sporty type of passenger car. For anyone interested in getting ahead a little



## For arm-chair drivers.

faster, there is a 2-litre, 70/67 bhp (DIN/SAE – net) engine available instead of the 1.6 litre, 50/48 bhp engine. And as far as safety is concerned, you will be relieved to know that the VW Commercial is up to passenger-car standard on this point too.

Behind its front bumper bar, there is a deformation element as wide as the car, which, in the event of a collision, absorbs most of the impact. Strong side members, reinforced chassis

profiles, reinforcements on the front wall and special stiffeners in the doors provide for maximum stability in the cab. The predetermined bending points have been designed so as to ensure that deformation takes place below the cab floor as far as possible. Just one more thing worth mentioning, and that is the VW Commercial's dual circuit brake system with brake pressure regulator and disc brakes in front.

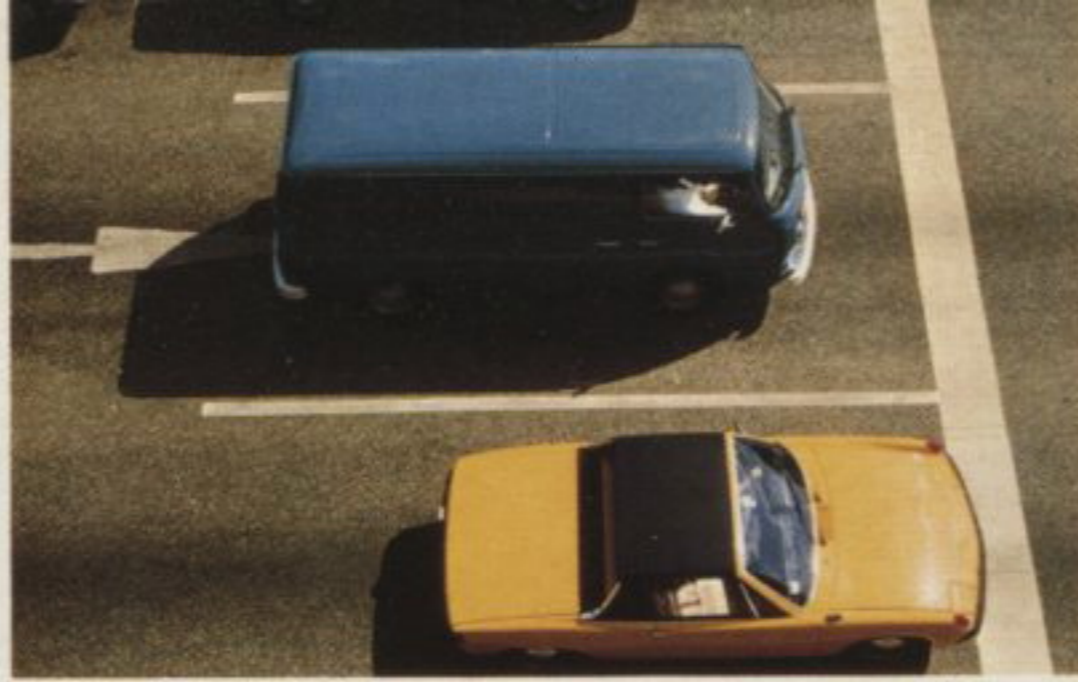

# The VW Commercials. They have already

When someone wants a VW Commercial, he usually wants it for one of the three following reasons.

Either he has some fragile goods to transport. And then he'll need the VW Delivery Van. Or,

even the High-Roofed Delivery Van, if they happen to be goods that need plenty of space.

Or he has more massive transports and needs the VW Pick-up, with either the standard or the enlarged platform.

Or, again, he may want to transport people.



# solved over 4 million transport problems.

And then the VW Microbus is the one he will want. For 7, 8 or 9 people.

Then, of course, there are even people who have to do a bit of both: transport people and bulky freight. Or people and fragile consignments. And for them there's the VW Double-Cab

Pick-up. With room for 6 and plenty of wide open space as well. Or the VW Kombi, which can be turned from a delivery van into a bus or vice versa at a hand's turn. So you can have the advantages of two Commercials in one.



## The VW Delivery Van.

You could not tell just by looking at it, but this short, compact car has 177 cu.ft. of loading space inside. And since it can carry payloads of up to 2205 lbs. (the special model even 2645 lbs.), it is certainly made to take a packet.

If you want more details: there is a loading area of 44.1 sq.ft. with a space over it averaging 55.1 ins. in height. Access is provided by the

sliding door at the side and the rear tailgate.

Both are simple to open: the tailgate opens upwards where it is automatically arrested. The sliding door, sideways where it catches in place.

And since you will often have only one free hand at your disposal, the sliding door has been made for one-handed operation. Not much effort is needed.





## Loads more than it looks.

Loading is no hard labour either. The loading ramp is at a conveniently low height over the road – 20 inches at the sliding door.

Do not be disappointed if the Delivery Van turns out to be too small for your particular needs. We have another one up our sleeve: the High-Roofed Delivery Van. With an additional 42 cu.ft. of space, and measuring 63.2 inches in height.

A taller sliding door (by about 12 ins.) is also available for this version.

Furthermore, there is an open passageway in all delivery vans from driver's cab to load compartment. And in the High-Roofed Delivery Van there are bulkheads to protect driver and front passenger, as well. So that the cargo stays where it should – in the load compartment.

45  
44  
43  
42  
41  
40  
39  
38



## The VW Pick-up. A bigger

The VW Pick-up can also take loads of up to 2205 lbs. Even if they are pretty bulky.

In the Pick-up, the loading surface is above the wheels which means that there are no wheel casings protruding into the loading platform, and the flat 45.2 sq.ft. of loading area is one

hundred percent available for use. The steel sideboards hinge down all round. The loading surface is just the right height for standard loading ramps: 38.6 ins. above the ground.

One very sensible feature you'll notice when loading, at the latest: the hardwood batten ribs. Heavy loads slide in more easily and won't be



## 45.2-sq.ft. platform is hard to find.

standing in water when it rains.

Tarpaulin and canopy frame, available as optional extras, provide for a cargo space of 168 cu.ft. in the VW Pick-up.

And for more fragile items and things that should not be left openly lying around, a special place has been provided: under the loading

surface there is a locker 51.2 ins. wide, 63 ins. deep and 13.4 ins high.

Everything we've said about the VW Pick-up goes for the VW Pick-up with enlarged platform, only more so: with a 56.2 sq.ft. platform it is ideal for transporting really bulky loads.



## The VW Double-Cab Pick-up. With for the

The VW Double-Cab Pick-up proves that the combination of two good ideas can often result in a third idea which is just as good.

If you start from the front, the VW Double-Cab Pick-up will look like a fine example of the VW

Microbus. With enough space to take a six-man crew, and in comfort too.

Towards the rear, this VW Microbus suddenly turns into a VW Pick-up. With all the characteristics and advantages of the VW Pick-up described on the previous page: hinged steel side-

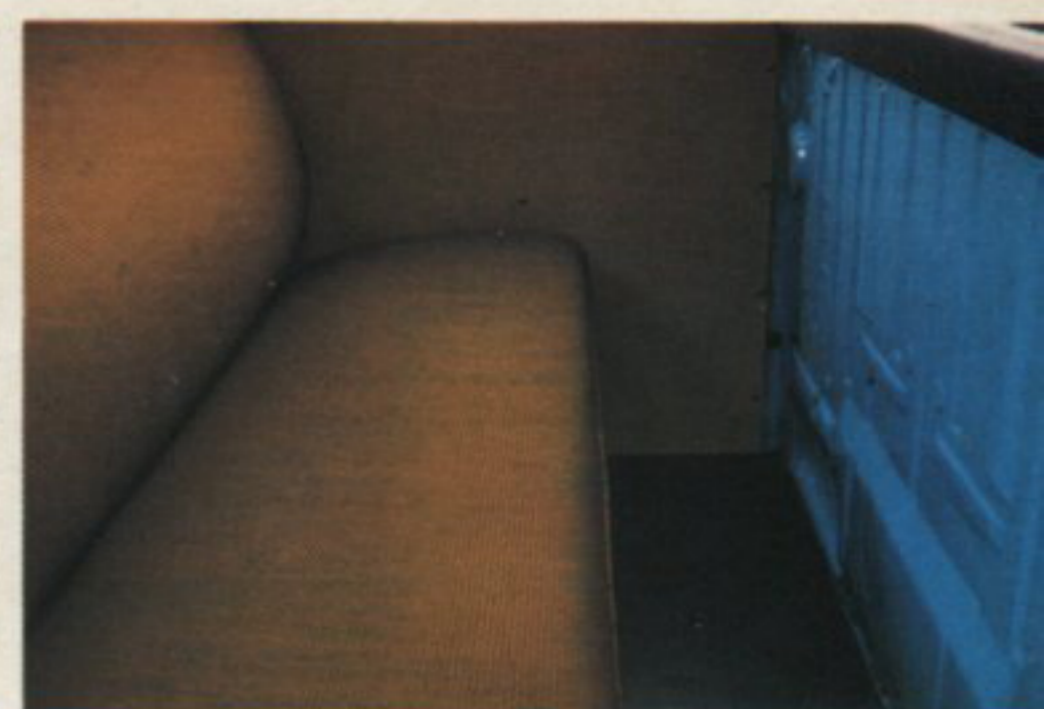

## the advantages of two Commercials price of one.

boards, large, flat load platform (31.2 sq.ft.). And with the tarpaulin and canopy frame (optional extra) you can take 113 cu.ft. of cargo. Capacity can be boosted by another 39.0 cu.ft. by using the rear cab for freight instead of people.

And if this much space is still not enough, take

a look under the rear bench seat. There you will be surprised to find another 11 cu.ft. of stowage space. All in all, enough space for a small gardening business to take its crew, seedlings, tools and tucker to work in comfort.

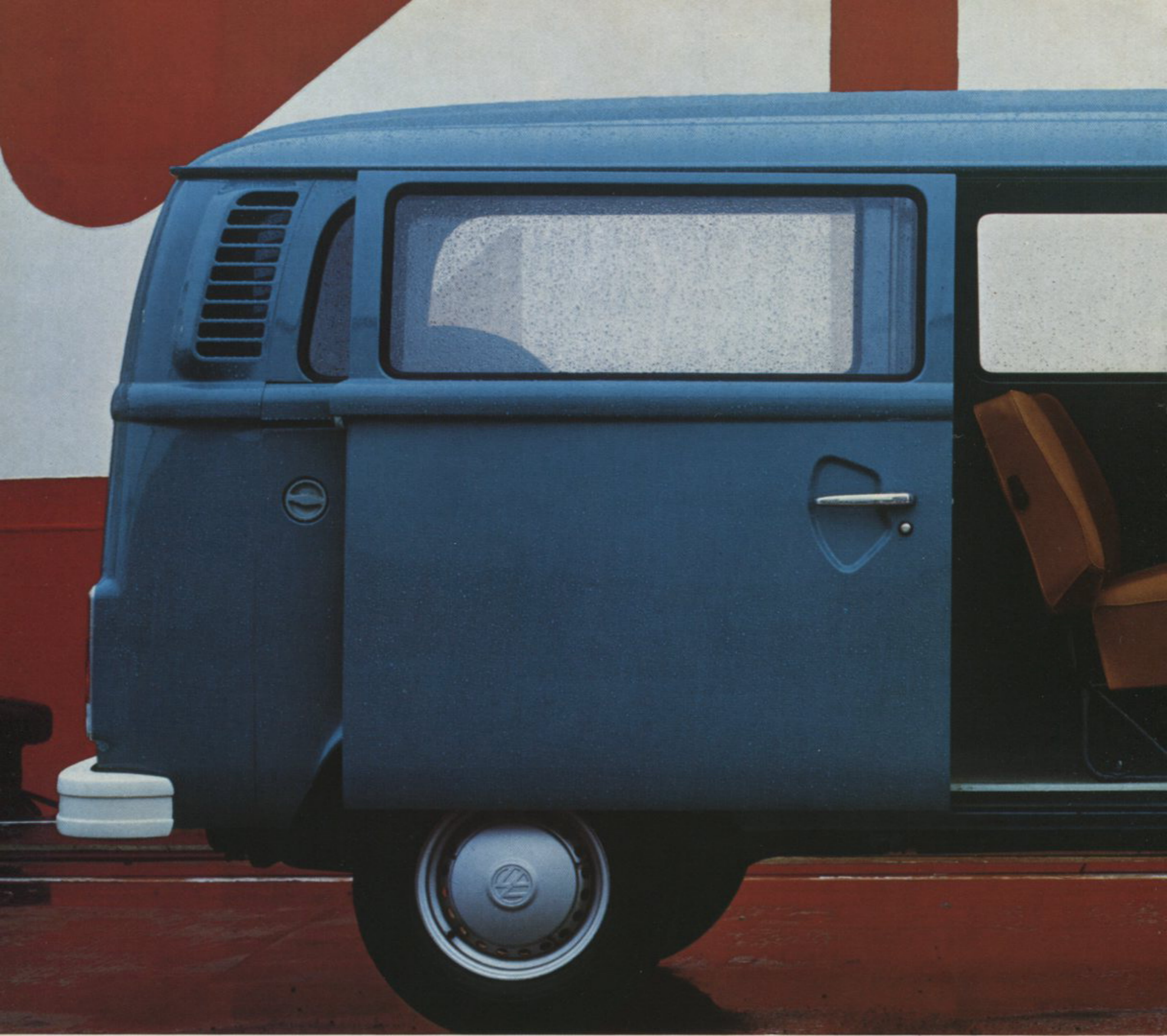

## The VW Kombi. The bus that

Like the VW Double-Cab Pick-up, the VW Kombi combines the advantages of two commercials in one.

On the one hand you have a bus for 9 people at your disposal – with as many as 8 different seating configurations to choose from.

On the other hand, it is just as reliable when it is put to work as a VW Commercial, capable

of taking up to 176.5 cu.ft. of freight weighing up to 2205 lbs. The special model can take even more: 2645 lbs.

Conversion from bus to van and back again could not be simpler. A couple of winged nuts are loosened and the seats can be removed. Another hand's turn, and they are back again in place.



## can be turned into a van.

The seats are very comfortable, by the way. Generously wide and with ample leg-room. An effective heating system and a no less effective ventilation system keep the atmosphere pleasant in both the driver's cab and in the passenger compartment.

There is only one difference between the van version of the VW Kombi and the original VW

Delivery Van: the side windows. Just like the VW Delivery Van, the VW Kombi has the rear tailgate and the side sliding door as standard features. The inside dimensions are the same too.

For the sake of completeness, it should be said that this variability is also available in the form of a high-roofed Kombi. Just in case anyone you know suffers from claustrophobia.



## The VW Microbus. So a couple

For form's sake, VW would like to include its outsize passenger car here. A seven, eight or nine seater. Everything you would normally expect to find in a passenger car, is to be found here, in the VW Microbus.

In the first place, it has plenty of room for you and your travelling companions. And plenty of comfort too.

The air is fresh and the temperature is kept pleasantly warm or cool, the way you like it. Since the powerful heating and ventilation systems control the interior climate the way you decide.

The interior is fully lined with plastic. The floor laid out with wall-to-wall rubber matting. And both provide effective insulation against heat and noise.



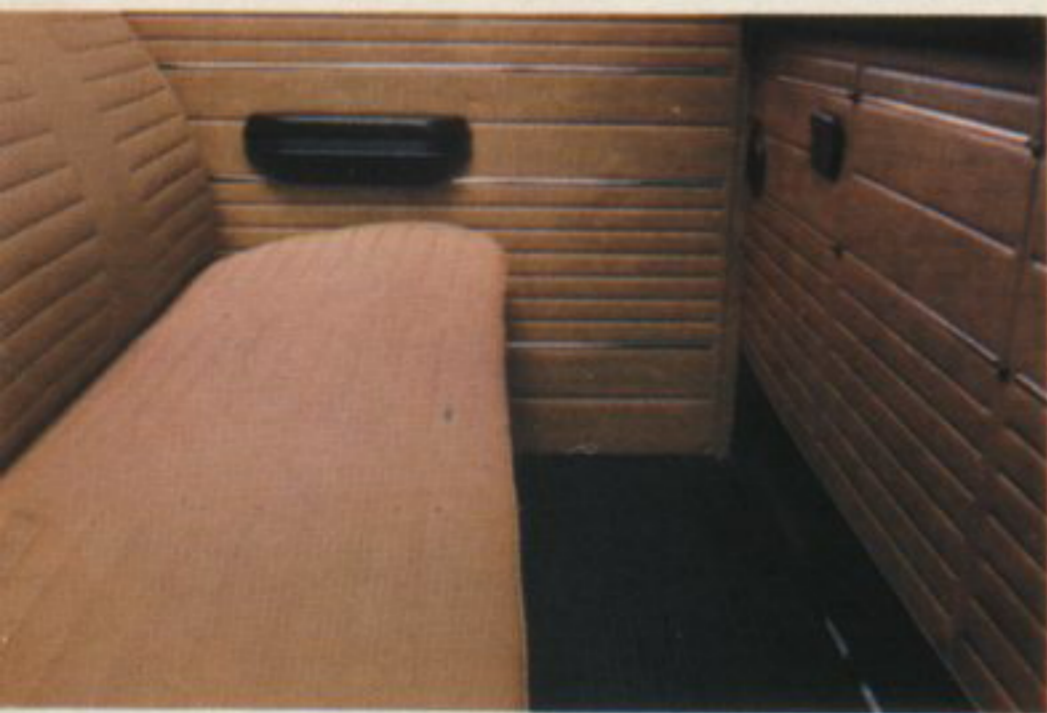

## of extra people can come along.

The seats are comfortably upholstered. Furthermore, there is a sophisticated chassis which absorbs all the bumps on the road.

Armrests and ashtrays everywhere, coat hooks and assist straps to ensure that no one is lacking in anything in the VW Microbus.

Especially in the L Microbus where there are a lot of additional practical details besides the polished and chrome trim outside: rubber strips

on bumpers, rubber profiles on mouldings, reversing lights, vent wings on windows, a clock, a trip mileage recorder, vanity mirror, and additional coat hooks.

All that is left to say on the Microbus is that we have not forgotten to provide the VW Microbus with luggage space: 35.5 cu.ft. With carpeting and polished window bars in the L version.

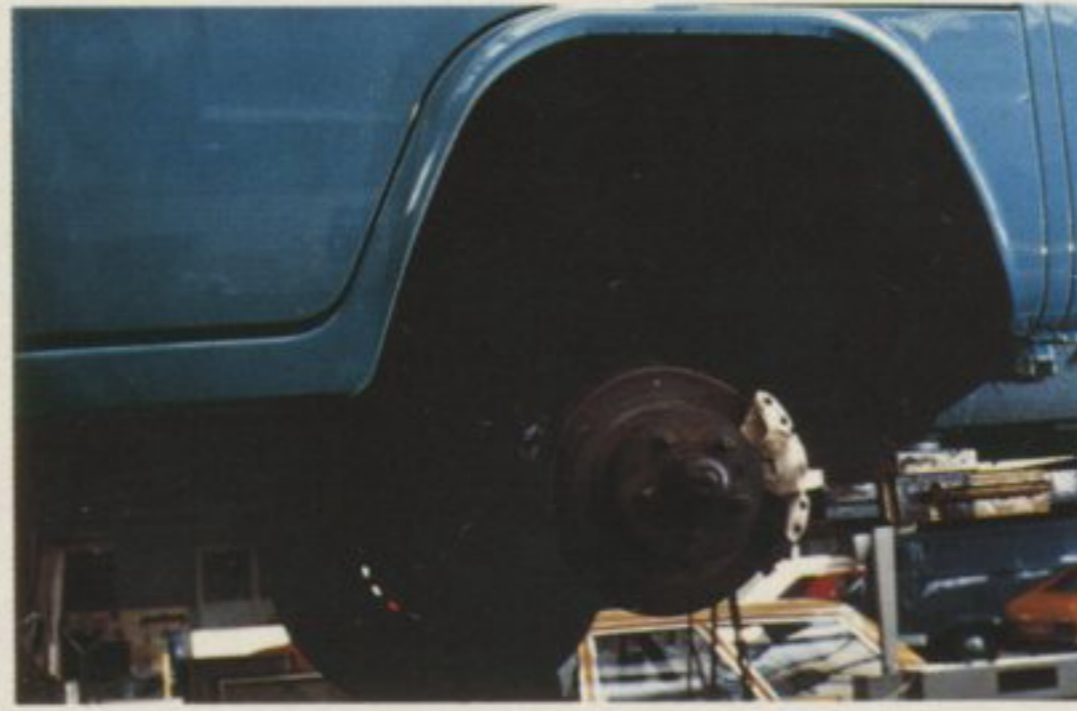
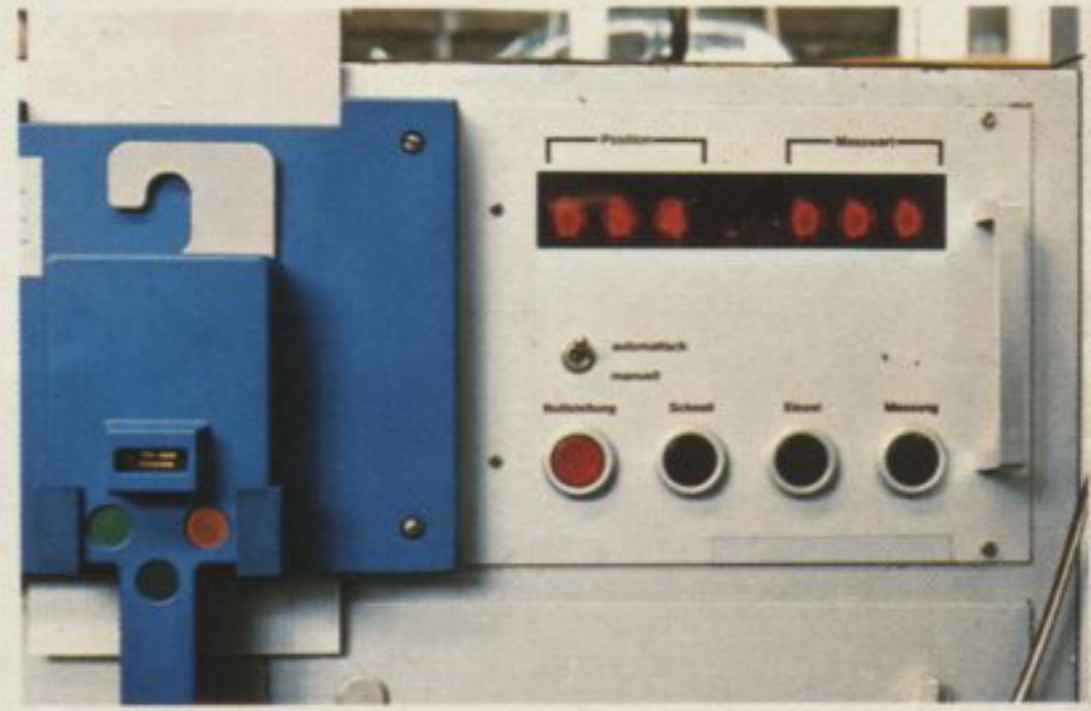

# The VW Commercial. With all the

To own a car from VW has always been something special. Because each and every VW is backed by the experience and efficiency of an organization operating in more than 140 countries, following the same meticulous VW rules.

### VW quality

It is included with each and every VW. It stands for top craftsmanship in production and extreme

accuracy in inspection. Before it's allowed to leave the factory, every VW is subjected to the critical scrutiny of numerous inspectors. This attention to detail is what makes your VW so tough and reliable. And why it maintains such a high resale value, if ever the time comes that you want to sell.

The proverbial VW quality comes not only with new Volkswagens but with genuine VW Ac-

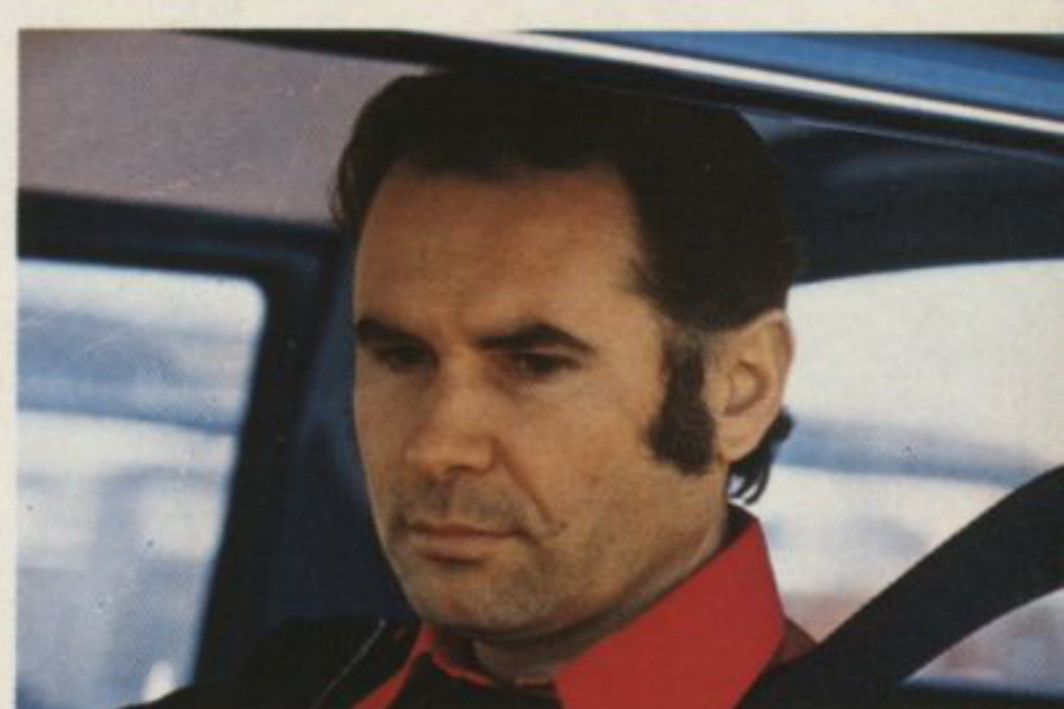
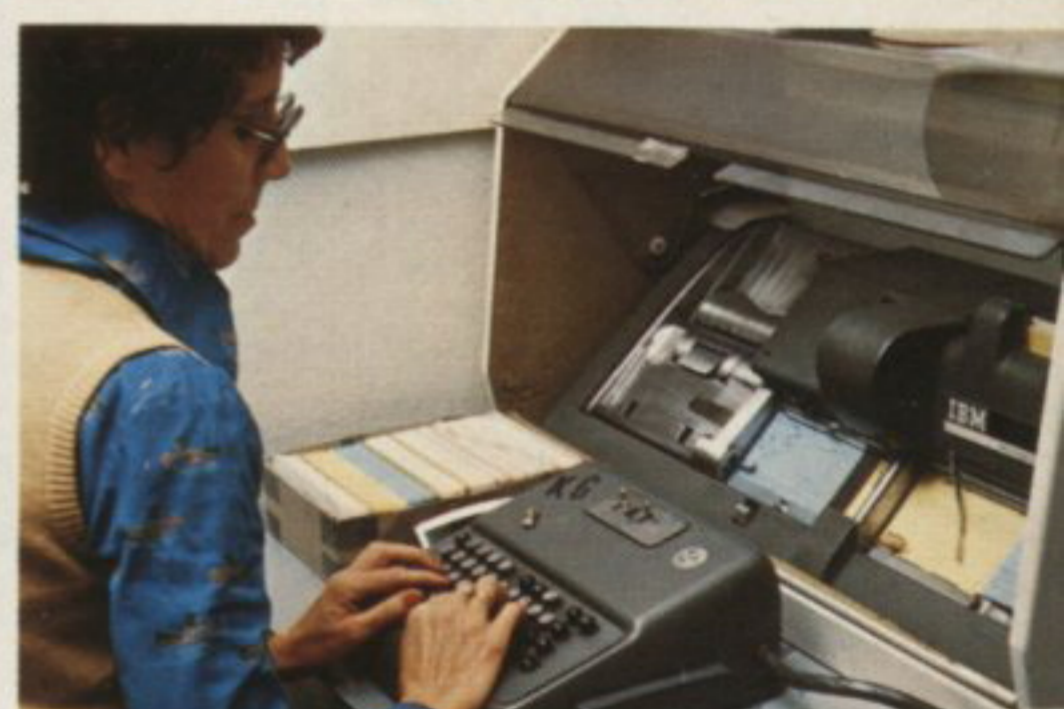
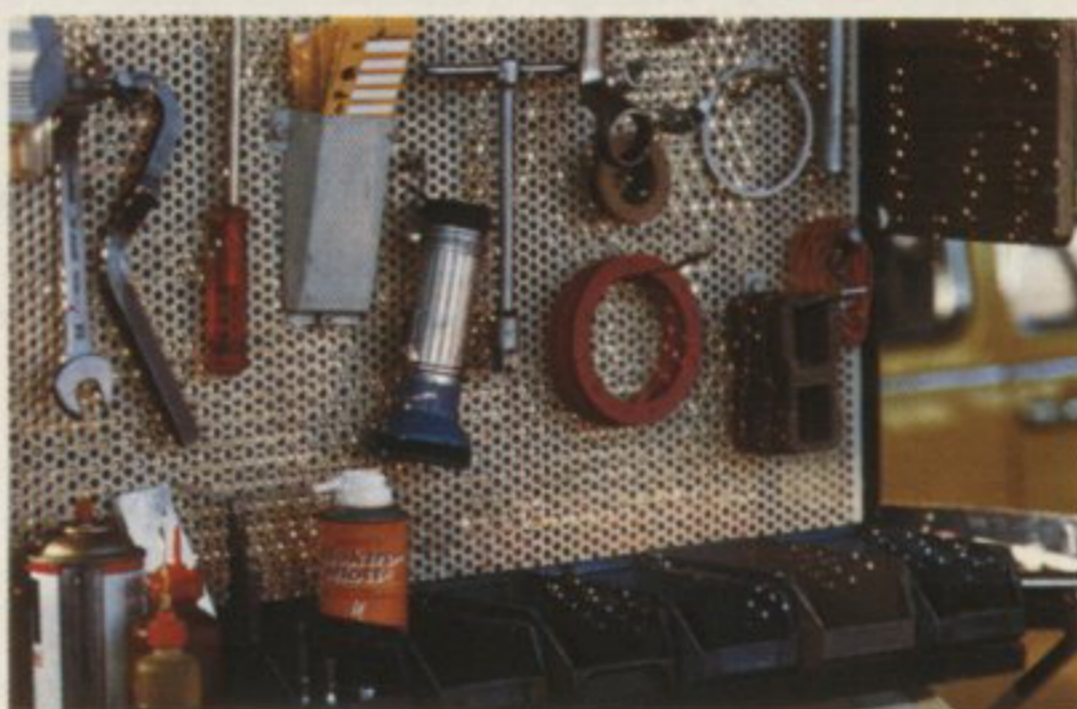

# service that only comes with the VW's.

cessories too. VW is always VW after all.

## VW Service

Volkswagens – the very cars which generally need less servicing than others – have one of the densest and most extensive service networks in the world at their disposal: VW Service combined with VW Quality.

With genuine VW Spare Parts that are controlled and checked as strictly as any VW car. And

guaranteed the same way. The VW Service also includes checked repair hours and perfect maintenance. This sort of a check of your VW guarantees reliability: through the famous VW Diagnosis.

As a result, errors will be almost completely eliminated. Don't you find so much service a big advantage?

# The VW Commercial. The

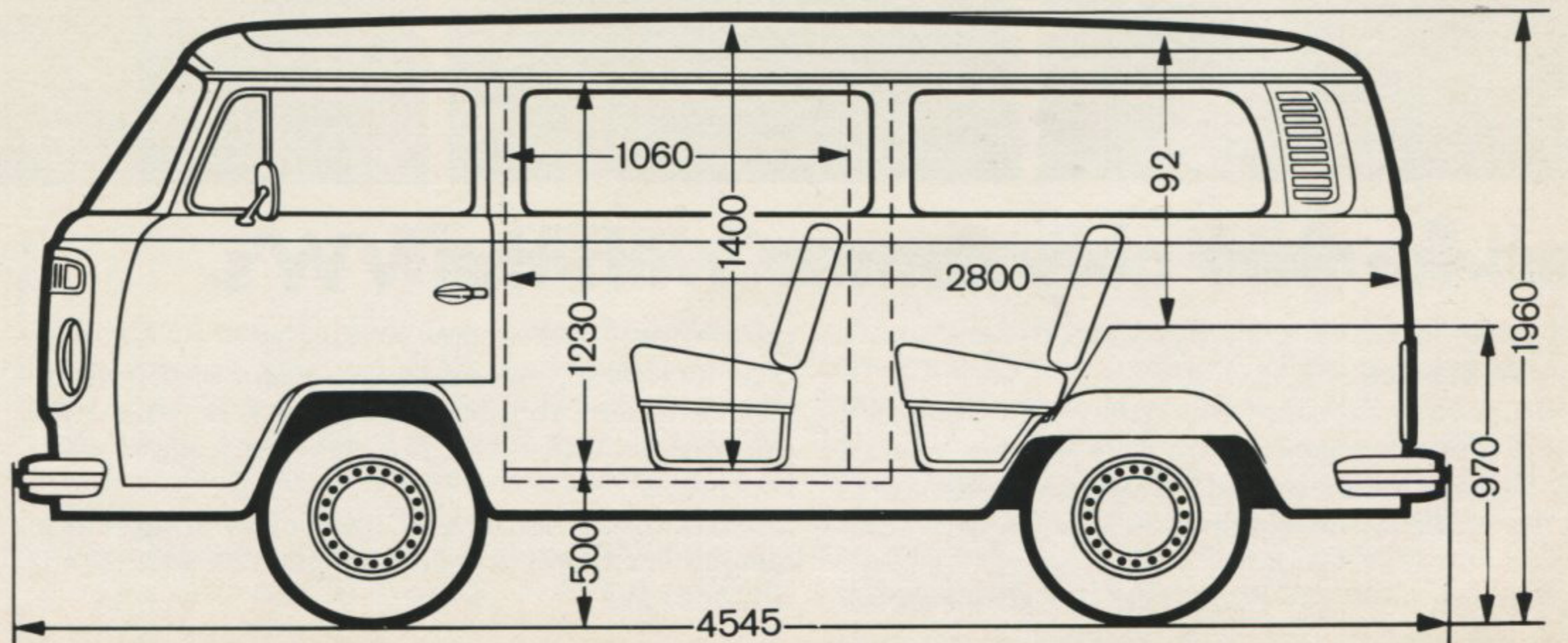
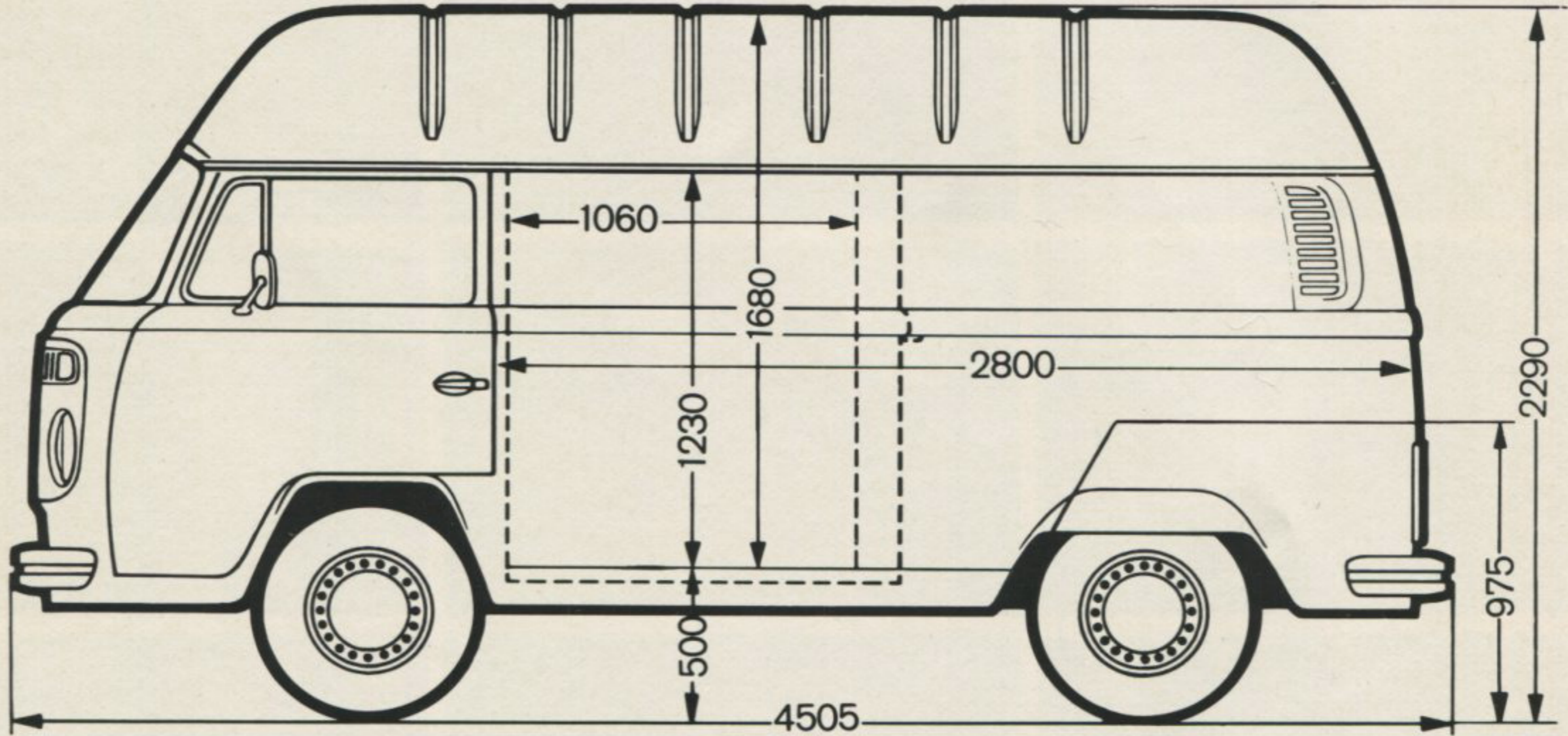
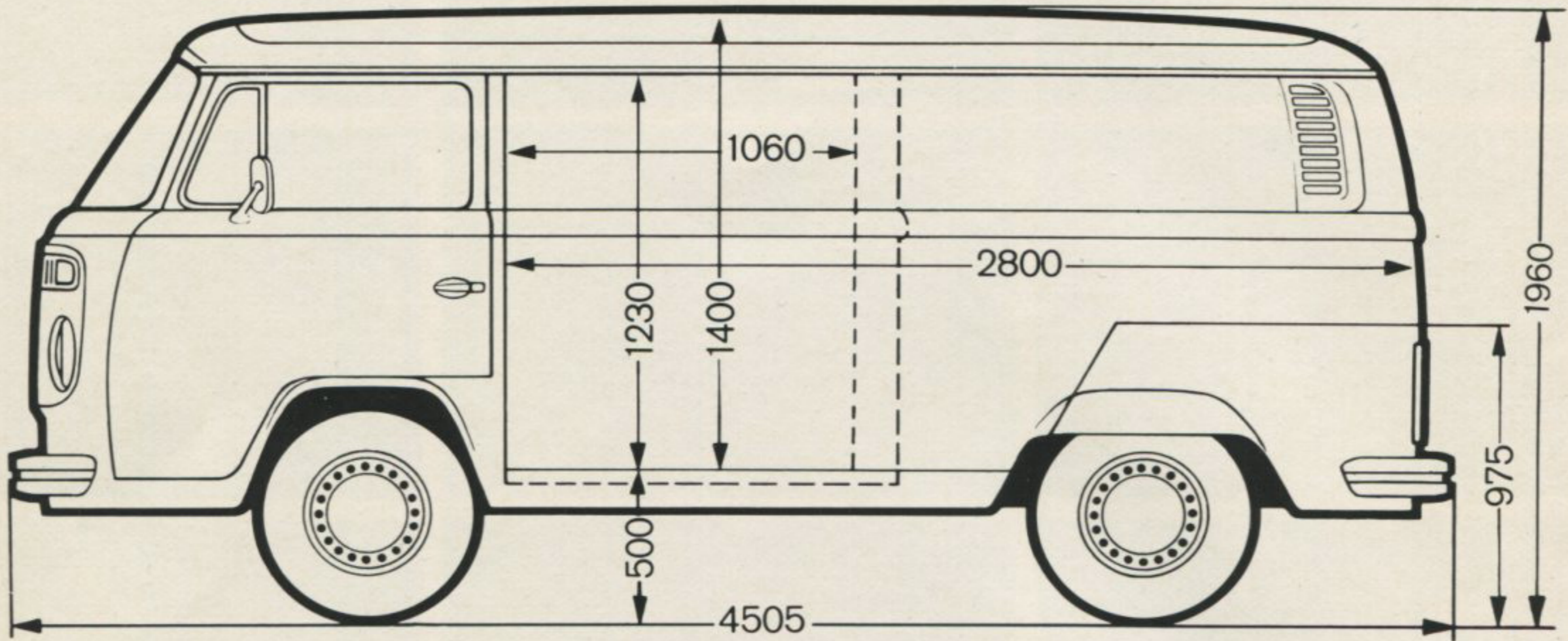

long and the short of it.

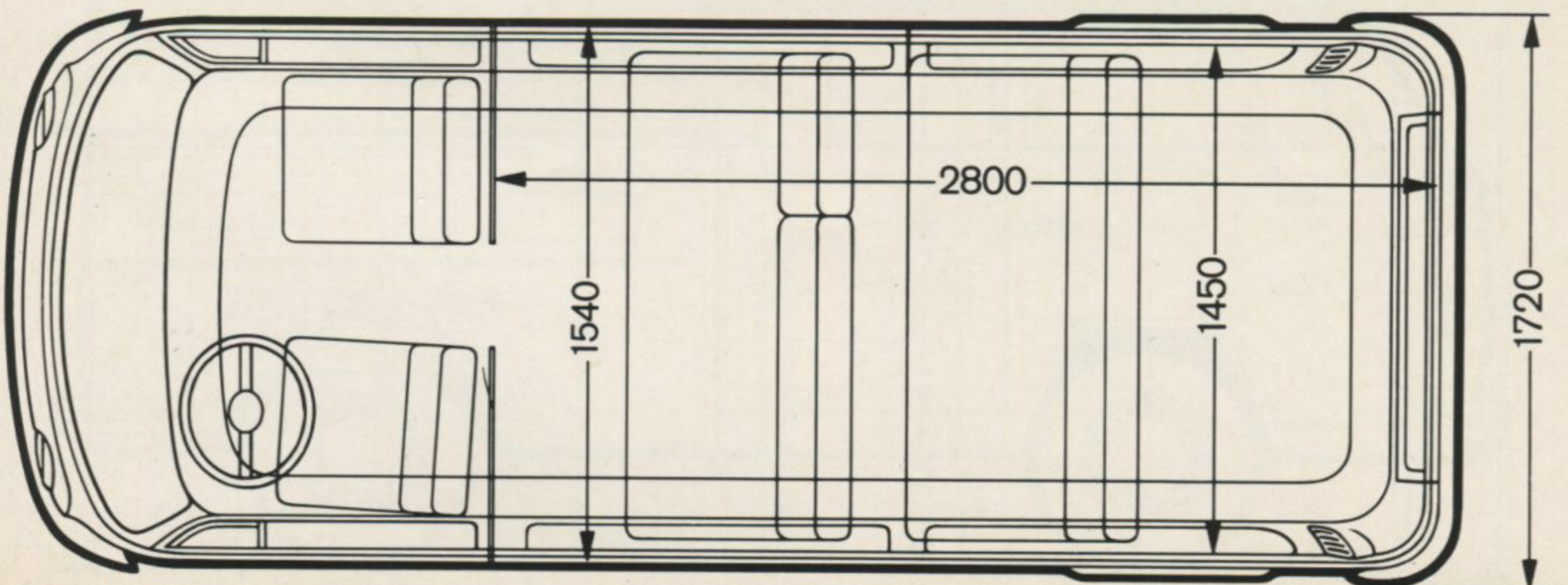
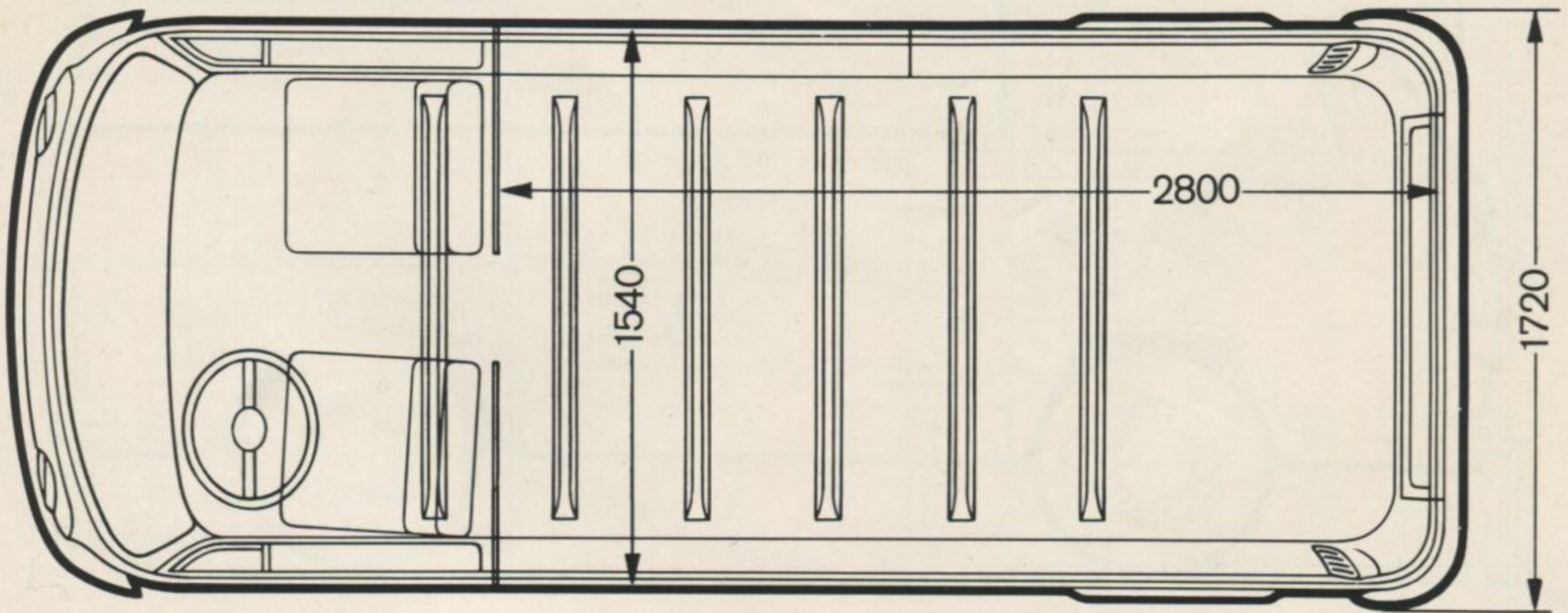
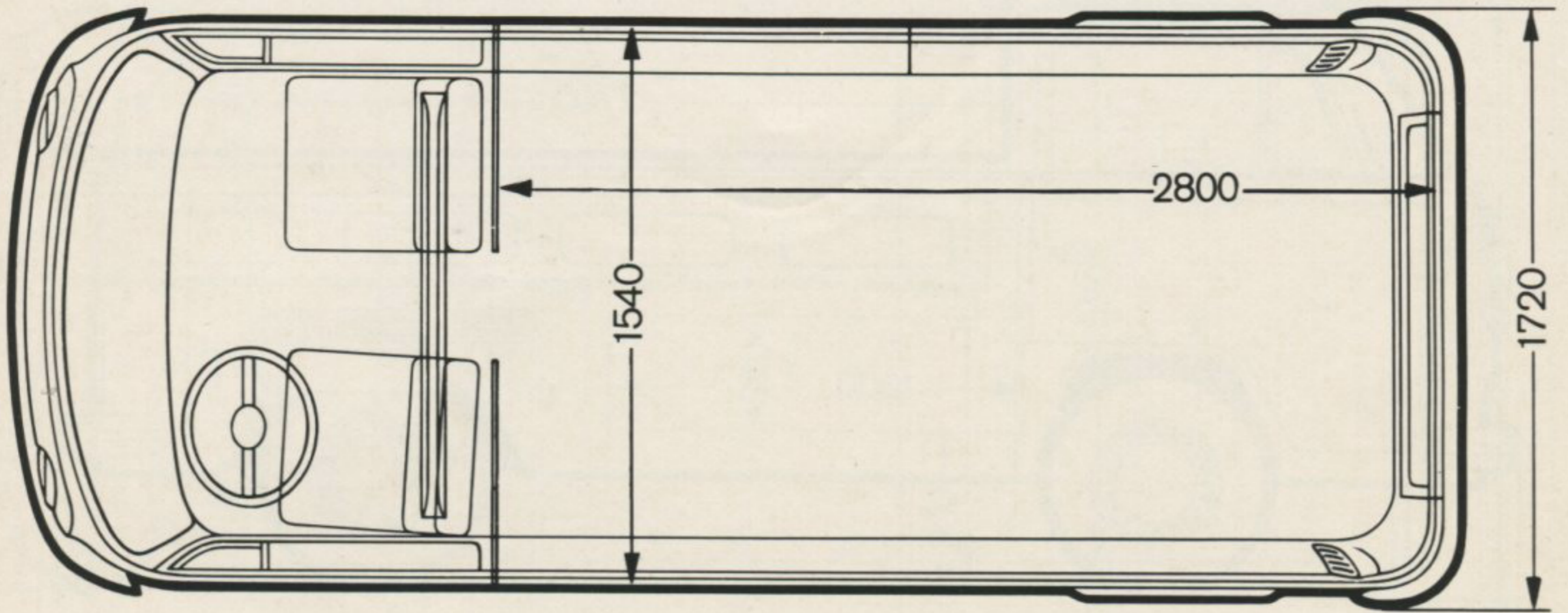

# The VW Commercial. The

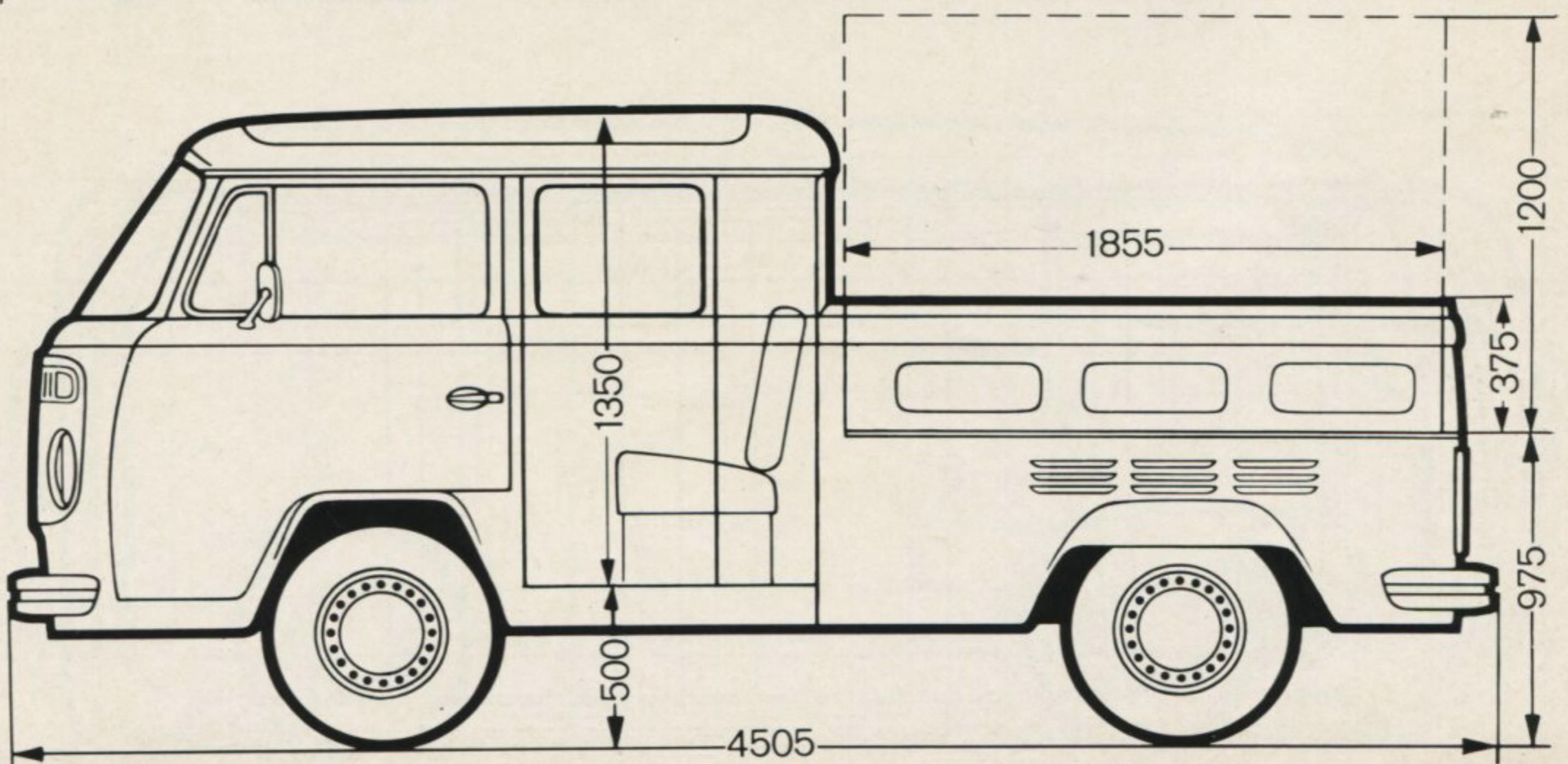
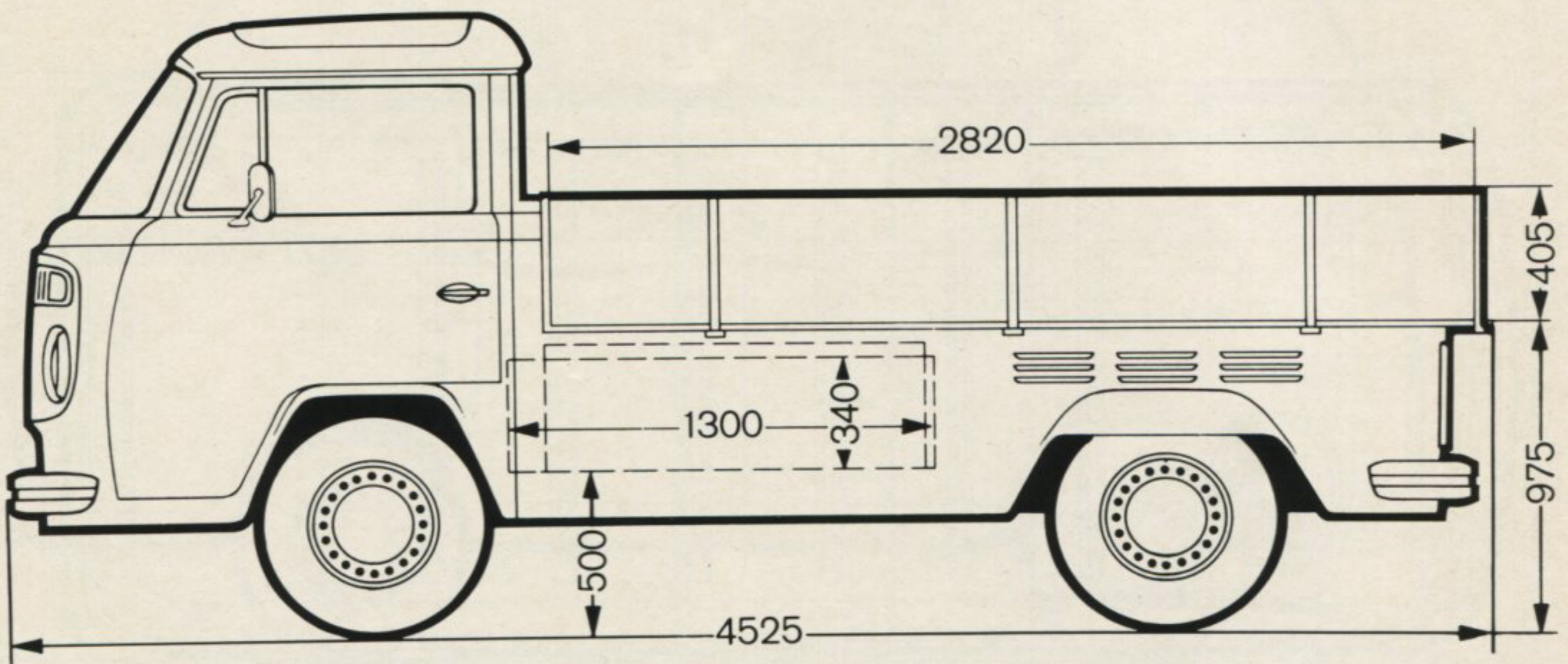
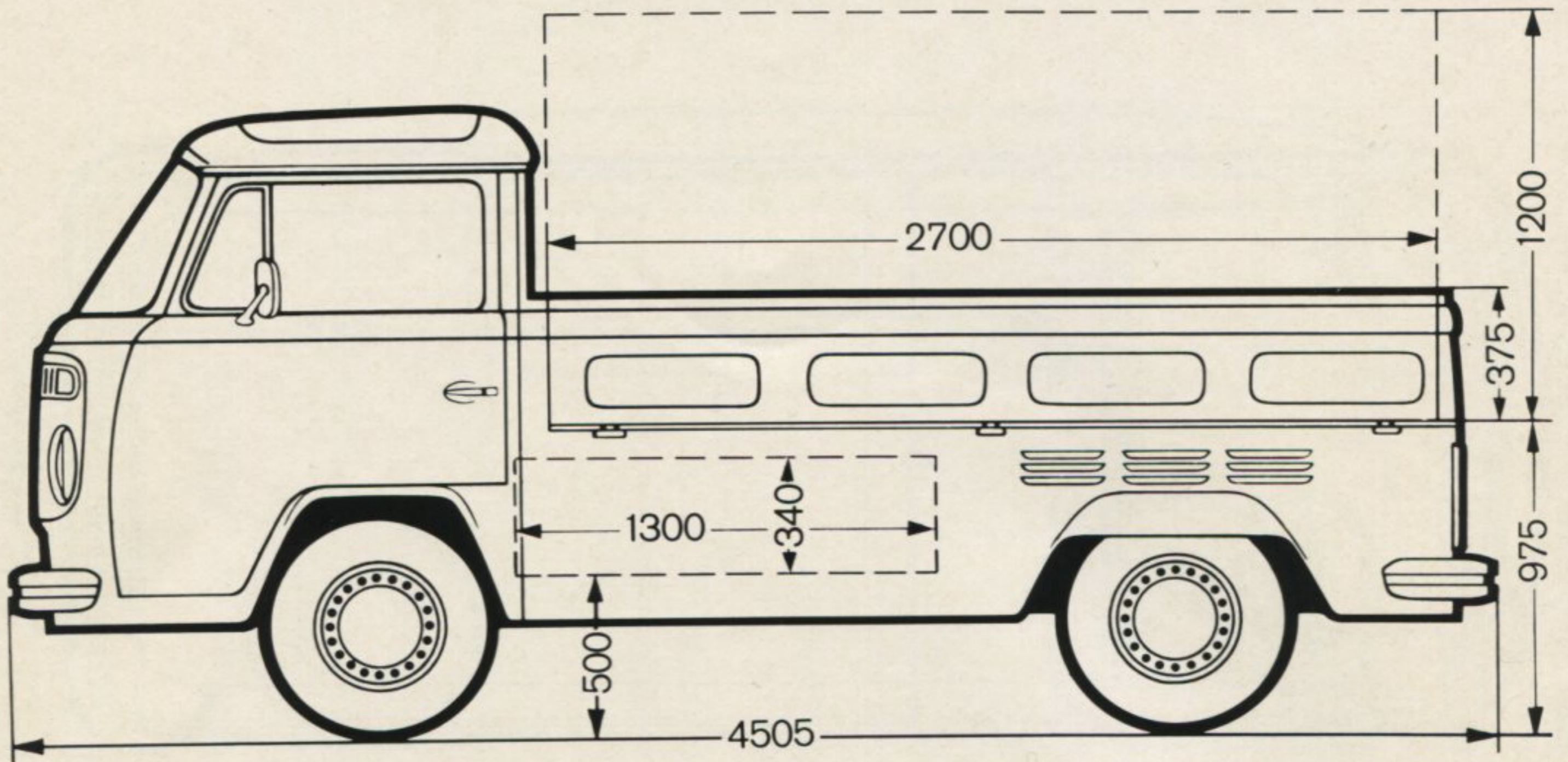

long and the short of it.

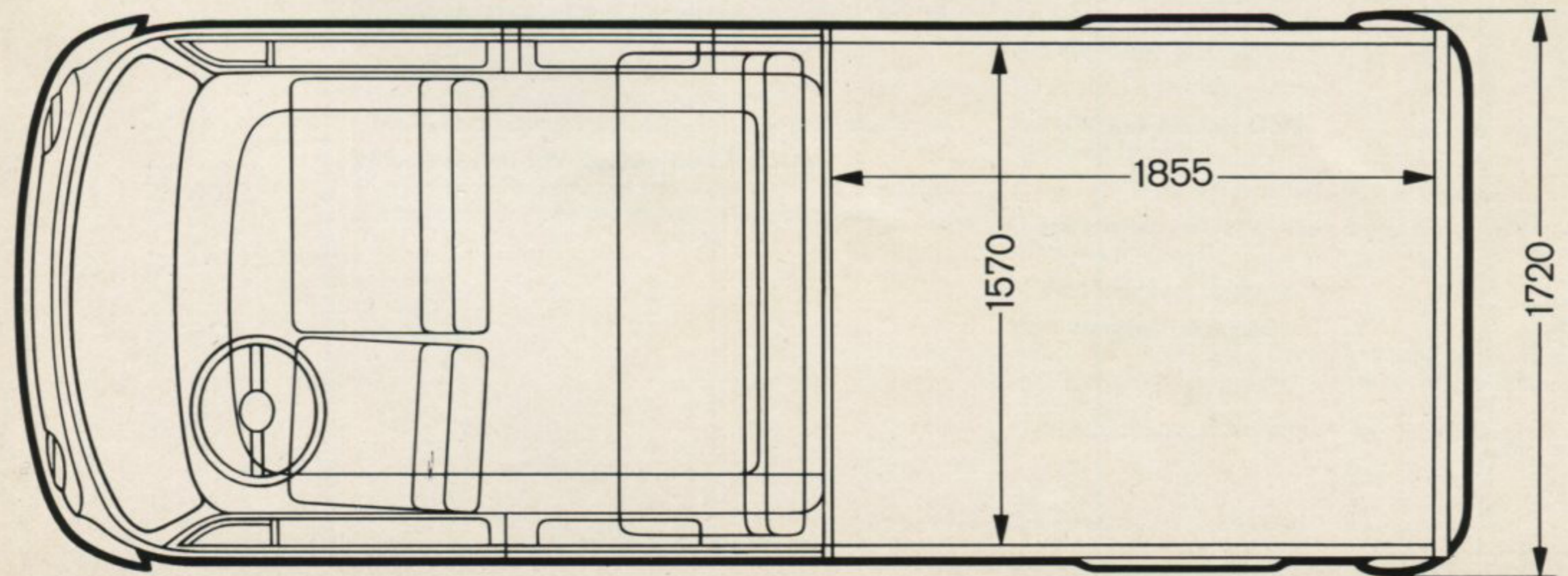
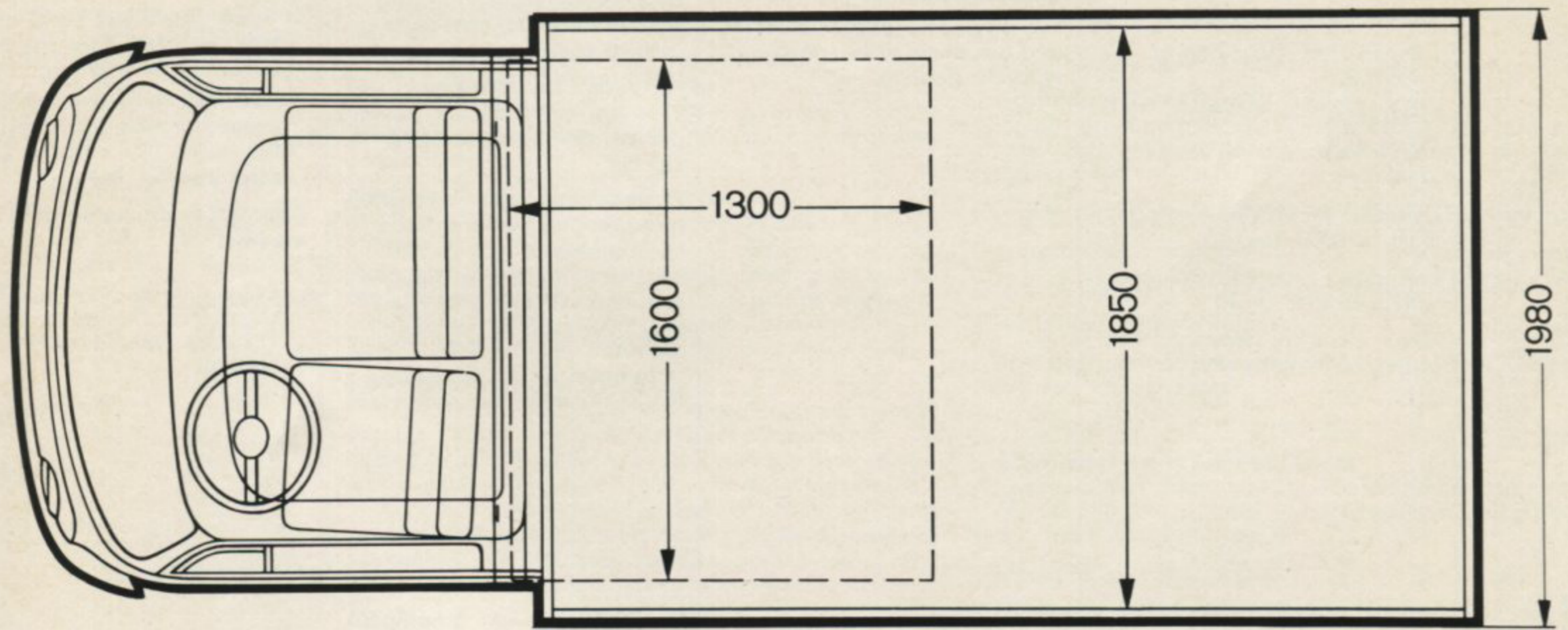
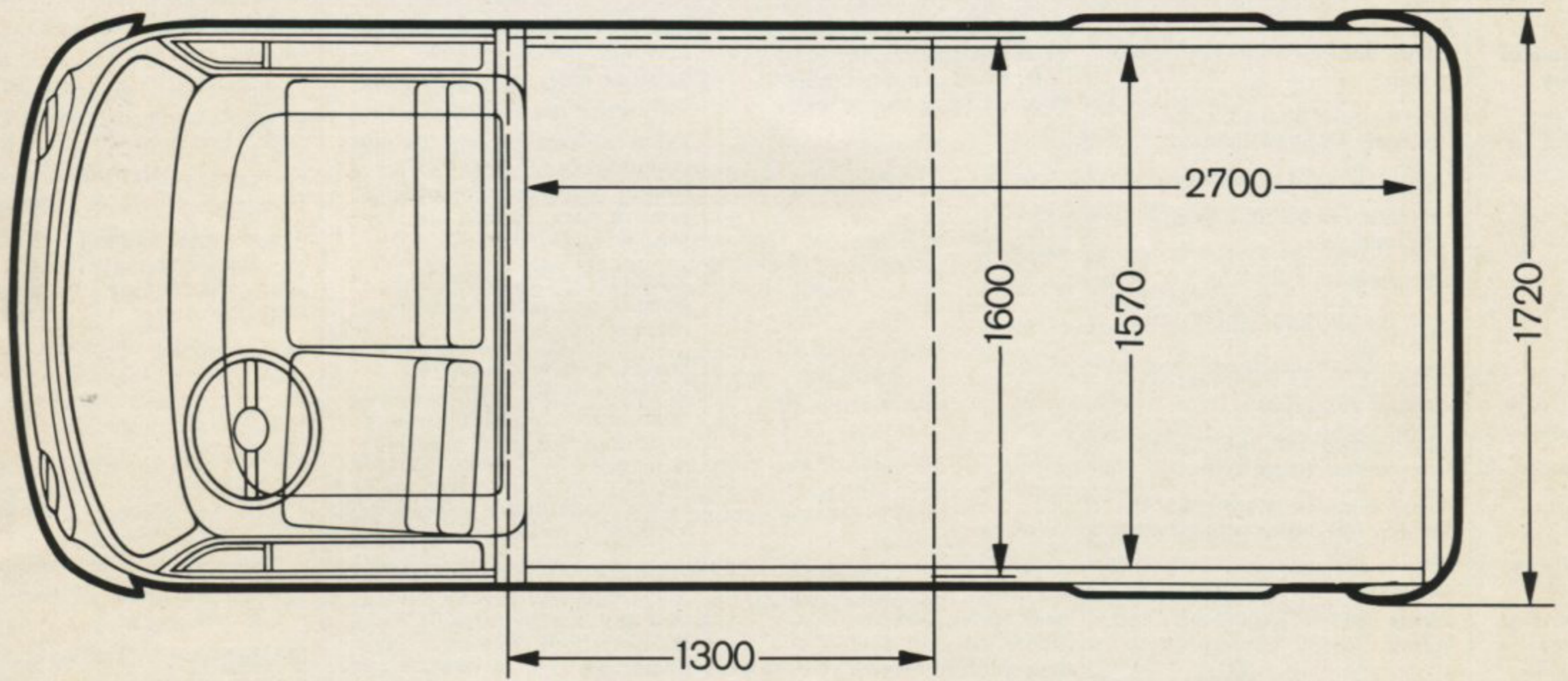

# The VW Commercials. Pick

Models	Engine and electrical system	Power transmission	Chassis	Performance
<b>VW Commercial 1.6 litres</b>	<ul style="list-style-type: none"> <li>┌ Air-cooled, four-cylinder, four-stroke, flat four engine mounted in rear</li> <li>┌ Bore x stroke 85.5 x 69 mm. Capacity 1.6 litres (1584 cc).</li> <li>┌ Output 37 kW<sup>1)</sup> at 4000 rpm.</li> <li>┌ DIN/SAE net 50/48 bhp at 4000 rpm.</li> <li>┌ Compression ratio 7.5:</li> <li>┌ Maximum torque 108 Nm<sup>1)</sup> at 2800 rpm.</li> <li>┌ DIN/SAE net 10.8/74.4 mkg/lbs.ft. at 2800 rpm.</li> <li>┌ Single down-draught carburettor with automatic choke.</li> <li>┌ 12-volt electrical system. 45 Ah battery. Alternator with 50 Amp.</li> </ul>	<ul style="list-style-type: none"> <li>┌ Via clutch, full baulk-synchromesh four-speed gearbox. Differential and double-joint drive shafts to rear wheels.</li> </ul>	<ul style="list-style-type: none"> <li>┌ Springing: torsion bars in front and rear, combined with double-acting telescopic shock absorbers.</li> <li>┌ Wheel suspension and location: by means of cranked trailing links up front and semi-trailing arms at back. Torsion bar stabilizer in front.</li> <li>┌ Steering: hydraulic steering damper and safety steering column.</li> <li>┌ Brakes: dual-circuit brake system with disc brakes up front, drum brakes at rear and deceleration-sensitive brake pressure regulator.</li> <li>┌ Tyres: diagonal-ply 7.00-14 8 PR, for bus "L": radial-ply 185 R 14 C.</li> </ul>	<ul style="list-style-type: none"> <li>┌ Maximum speed 68 mph (110 km/h).</li> <li>┌ Optimum hill climbing ability on good roads, fully laden and in first gear: 26 %.</li> <li>┌ Fuel consumption<sup>2)</sup> (regular fuel) 24.8 mpg imp. (11.4 l/100 km).</li> <li>┌ Specific consumption on level ground at a steady 50 mph (80 km/h): 27.7 mpg imp. (10.3 l/100 km).</li> </ul>
<b>VW Commercial 2.0 litres</b>	<ul style="list-style-type: none"> <li>┌ Air-cooled, four-cylinder, four-stroke, flat four engine mounted in rear.</li> <li>┌ Bore x stroke 94 x 71 mm. Capacity 2.0 litres (1970 cc).</li> <li>┌ Output 51 kW<sup>1)</sup> at 4200 rpm.</li> <li>┌ DIN/SAE net 70/67 bhp at 4200 rpm.</li> <li>┌ Compression ratio 7.3.</li> <li>┌ Maximum torque 143 Nm<sup>1)</sup> at 2800 rpm.</li> <li>┌ DIN/SAE net 14.3/98.6 mkg/lbs.ft. at 2800 rpm.</li> <li>┌ Twin down-draught carburettors with automatic choke.</li> <li>┌ 12-volt electrical system. 45 Ah battery. Alternator with 55 Amp.</li> </ul>	<ul style="list-style-type: none"> <li>┌ Via clutch, full-baulk synchromesh four-speed gearbox. Differential and double-joint drive shaft to rear wheels.</li> <li>┌ <b>Optional at extra charge:</b> Automatic transmission with hydrodynamic torque converter and automatic three-speed epicyclic gearing.</li> </ul>	<ul style="list-style-type: none"> <li>┌ Springing: torsion bars front and rear, combined with double-acting telescopic shock absorbers.</li> <li>┌ Wheel suspension and location by means of cranked trailing links up front and semi-trailing arms at back. Torsion bar stabilizer on front axle.</li> <li>┌ Steering: with hydraulic steering damper and safety steering column.</li> <li>┌ Brakes: dual-circuit brake system with disc brakes in front and drum brakes at rear, deceleration-sensitive brake pressure regulator. Vacuum brake servo.</li> <li>┌ Tyres: 185 R 14 C (radial ply).</li> <li>┌ Differences on Bus "L" models: 185 SR 14 reinforced (radial ply).</li> </ul>	<ul style="list-style-type: none"> <li>┌ a) Maximum speed 79 mph (127 km/h).</li> <li>┌ b) Optimum hill climbing ability on good roads, fully laden and in first gear: 28.5 %.</li> <li>┌ c) Fuel consumption<sup>2)</sup> (regular fuel) 22.6 mpg imp. (12.5 litres/100 km).</li> <li>┌ d) Specific consumption on level ground at a steady 50 mph (80 km/h): 28.2 mpg imp. (10.0 litres/100 km).</li> </ul> <p><b>Differences on Automatic models:</b></p> <ul style="list-style-type: none"> <li>┌ a) 76 mph (122 km/h).</li> <li>┌ b) forward 25 %.</li> <li>┌ c) 21.2 mpg. imp. (13.3 litres/100 km).</li> </ul>

<sup>1)</sup> New unit for indication of engine output, maximum torque and rev speed respectively.

<sup>2)</sup> With half payload at steady 3/4 of top speed (but not more than 110 km/h), measured consumption plus 10 %.



# the model that is right for you.

Dimensions and weights	Special features of equipment	Optional items at extra charge
<p>These figures are quoted in the catalogue main text. Common data:</p> <p>Wheel base: 94.5 ins. (2400 mm). Track front/rear 54.9/57.3 ins. (1395/1455 mm).</p> <p>Maximum permissible trailer load for trailers of all types with brakes: 2205 lbs. (1000 kg). For 1.2 tons payload: 1764 lbs. (800 kg).</p> <p>Roof load for all self-contained constructions 220 lbs. (100 kg). Double-Cab Pick-Up: 165 lbs. (75 kg).</p> <p>No roof loads possible for Pick-Up, High-Roofed Delivery Van and Kombi models.</p>	<p><b>For all models:</b></p> <ul style="list-style-type: none"> <li>Two rear view mirrors. Steps in cab. Safety door handles. Screw-type safety belt mountings for all seats. Underseal for body and wheel housings.</li> </ul> <p><b>Cab for all models:</b></p> <ul style="list-style-type: none"> <li>Plastic lining throughout, footwells lined with plastic foil. Floor lined with insulating rubber matting.</li> <li>Driver's seat adjustable to nine positions, backrest fully adjustable, passenger's seat adjustable to two positions. On Pick-Up models two-seat passenger bench. Leatherette seat covers.</li> <li>Widely variable heating and ventilation system, ventilation air flow distribution to all directions. Adjustable, draught-free ventilation system in the cab doors. Particularly effective windscreen defrosting.</li> <li>Safety door locks; clothes hooks, door pulling handles, safety rear view mirror, sliding ashtray. Passenger grab handle. Glovebox. Non-glare, padded instrument panel cover.</li> </ul>	<p><b>For all models:</b></p> <ul style="list-style-type: none"> <li>Halogen headlights.</li> <li>Laminated windscreen.</li> <li>Lockable fuel tank cap/engine compartment lid.</li> <li>Heatable rear window.</li> <li>Two reverse lights*).</li> <li>Automatic transmission (only for 2.0 litres engine).</li> <li>Trailer connection.</li> <li>Anti-corrosion treatment for body cavities.</li> <li>Radial ply tyres*) (standard for 2.0 litres models).</li> <li>Vacuum brake servo (standard for 2.0 litres models). Dual circuit brake signal lamp (standard for brake servo).</li> <li>Limited slip differential (not in conjunction with automatic transmission).</li> <li>Day/night rear view mirror.</li> <li>Safety padding for instrument panel.</li> <li>Trip mileage recorder and clock*).</li> <li>Stationary and auxiliary heater.</li> <li>Complete radio installation.</li> <li>Blower for fresh air ventilation.</li> <li>Vent windows in the cab doors*).</li> <li>Automatically operated step below sliding door.</li> </ul>
<p>These figures are quoted in the catalogue main text.</p> <p>Wheel base: 94.5 ins. (2400 mm). Track front/rear 54.9/57.3 ins. (1395/1455 mm).</p> <p>Permissible trailer load for trailers of all types with brakes: 2645 lbs. (1200 kg). For 1.2 tons payload: 2205 lbs. (1000 kg). For automatic gearbox: 1340 lbs. (600 kg).</p> <p>Roof loads for all self-contained constructions: 220 lbs. (100 kg). For Double-Cabs: 165 lbs. (75 kg).</p> <p>No roof loads possible for Pick-Up, High-Roofed Delivery Van and Kombi models.</p>	<ul style="list-style-type: none"> <li>Headlight flasher. Courtesy light with door contact switch. Self-cancelling turn signals, lane-changing and hazard warning light system. Fuel gauge.</li> <li>Windscreen washer. Windscreen wiper with two speeds and brief-wipe setting (tip wiping) and automatic resetting.</li> <li>Access to load or passenger compartment. (Not for Pick-Up and Double-Cab models).</li> </ul> <p><b>Load compartment Delivery Van:</b></p> <ul style="list-style-type: none"> <li>Lateral sliding door, rear door opening upwards and self-locking over full car width. Interior light with sliding door contact switch.</li> </ul> <p><b>Additional items on VW Kombi:</b></p> <ul style="list-style-type: none"> <li>Like Delivery Van, but with 4 additional side windows. Safety belt anchorage points for all seats in passenger/load compartment. At extra charge: Seating equipment for 5 to 9 persons depending on size and arrangement including upholstery; heating by (driver-operated) heating nozzles in the load/passenger compartment.</li> </ul> <p><b>Additional items on VW-Bus:</b></p> <ul style="list-style-type: none"> <li>Like Kombi, but more comfortable seating equipment as standard. Plastic lining of passenger compartment throughout. Floor entirely covered with soundproofing rubber matting. Hot air nozzles in front of front bench and under middle bench. Two fresh air ducts, separately variable, with adjustable flow direction. Wide range of equipment (armrests, grab handles, clothes hooks, ashtrays). Chromium-plated hub caps and exterior mirrors.</li> </ul> <p><b>Additional items on VW Bus "L" models:</b></p> <ul style="list-style-type: none"> <li>Chrome VW inscription, vent windows in cab doors. Vent window frames and window sash frame in bright eloxised finish. Chrome bumpers with rubber lining. Trims with rubber strips. Passenger sun visor with vanity mirror. Electric clock. Trip mileage recorder. Two coat hooks. Aluminium step moulding at sliding door. Trims at side lining. Blank protective bars at rear window. Carpeting in luggage compartment. Radial ply tyres. Two reverse lights.</li> </ul> <p><b>Differences on VW Pick-Up:</b></p> <ul style="list-style-type: none"> <li>Three-seater cab with open load platform. Additional, lockable load compartment (locker) beneath platform.</li> </ul> <p><b>Differences on VW Double-Cab Pick-Up:</b></p> <ul style="list-style-type: none"> <li>Shorter load platform, but six-seater cab with stowage space beneath three-seater bench in second cab.</li> </ul>	<ul style="list-style-type: none"> <li>Safety padding for instrument panel.</li> <li>Trip mileage recorder and clock*).</li> <li>Stationary and auxiliary heater.</li> <li>Complete radio installation.</li> <li>Blower for fresh air ventilation.</li> <li>Vent windows in the cab doors*).</li> <li>Automatically operated step below sliding door.</li> </ul> <p><b>Additional items for VW Delivery Van:</b></p> <ul style="list-style-type: none"> <li>1.2 tons payload (not for High-Roofed Delivery Van and not in conjunction with automatic transmission and second sliding door).</li> <li>Higher sliding door (only for High-Roofed Delivery Van).</li> <li>Second sliding door (not for High-Roofed Delivery Van).</li> <li>Side and/or roof lining for load compartment.</li> <li>Full or half-height cab partition.</li> <li>Vent ducts in load compartment in conjunction with the armrests at cab doors.</li> <li>Heating ducts for load compartment.</li> </ul> <p><b>Additional items for VW Kombi:</b></p> <ul style="list-style-type: none"> <li>1.2 tons payload (not for High-Roofed Kombi and not in conjunction with automatic transmission, second sliding door and steel sliding roof).</li> <li>Steel sliding roof.</li> <li>Three vent windows in load or passenger compartment.</li> <li>Folding rear seat backrest.</li> <li>Floor matting for load or passenger compartment.</li> <li>Second sliding door (not for High-Roofed Kombi).</li> <li>Plastic headlining (not for High-Roofed Kombi).</li> <li>Full or half height cab partition.</li> </ul> <p><b>For VW Pick-Up and Double Cab Only:</b></p> <ul style="list-style-type: none"> <li>Second locker lid (Pick-Up only).</li> <li>Tarpaulin and canopy frame.</li> </ul> <p><b>For VW Bus models Only:</b></p> <ul style="list-style-type: none"> <li>Two-tone finish*).</li> <li>Three vent windows in passenger compartment.</li> <li>Tinted windscreen for sunlight protection and/or tinted windows all-round.</li> <li>Folding rear seat backrest.</li> </ul> <p><b>Bad-weather package<sup>3)</sup>:</b></p> <ul style="list-style-type: none"> <li>Intermittent wash/wipe device with automatic wash/wipe setting. Halogen fog lights. Heatable rear window.</li> </ul> <p>*1) Standard equipment for VW Bus "L" models.</p>

3) This package may vary somewhat from country to country.

# The VW Commercials. Pick the

Leatherette upholstery.



black

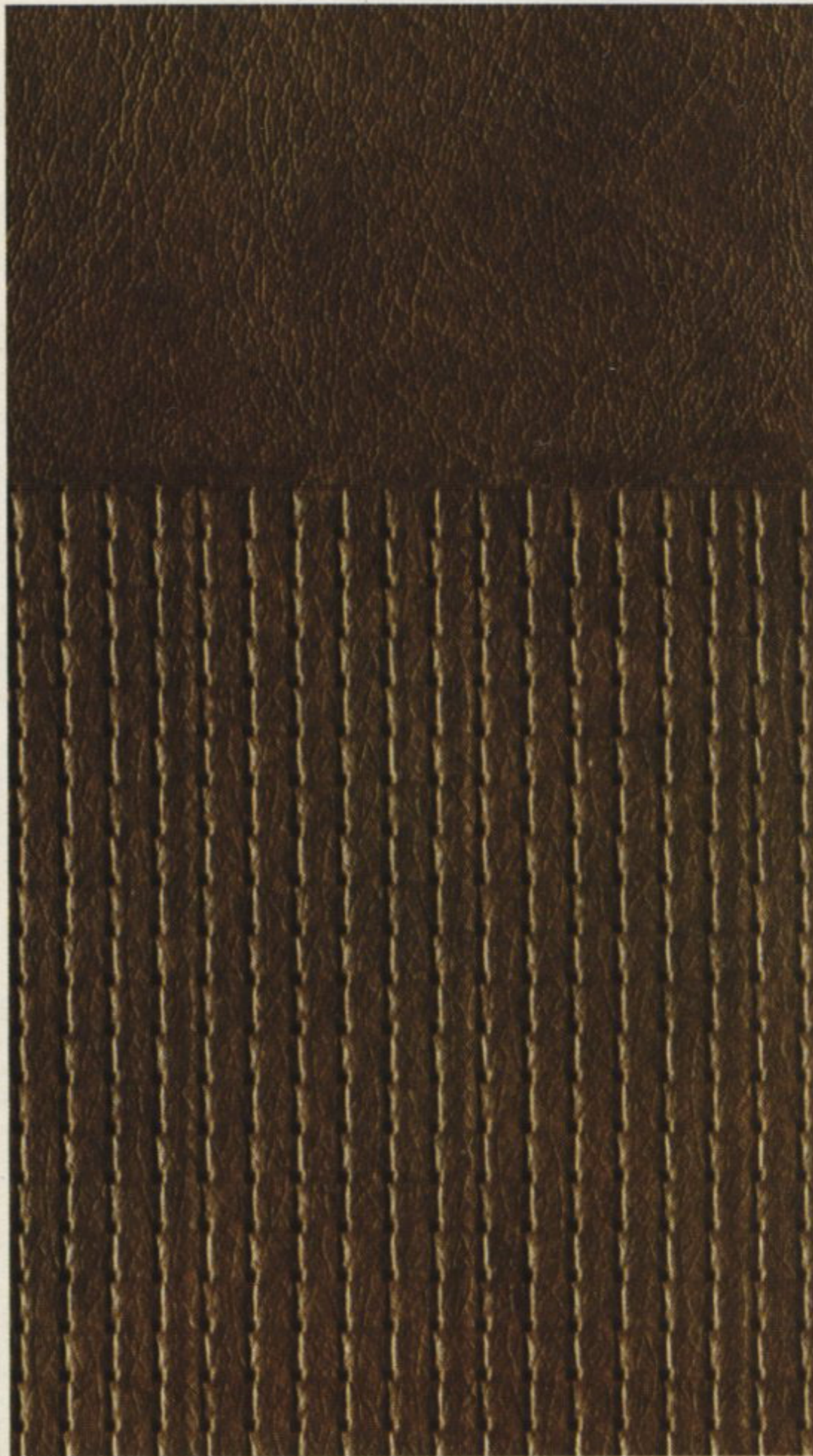

canyon brown

--50

--77

Possible colour combinations	Exterior colours	VW Commercial					VW Microbus/L				
		light grey	marino yellow	neptune blue	taiga green	pastel white	marino yellow	senegal red	ocean blue	taiga green	pastel white
<b>Upholstery</b>											
Leatherette	black	--50									
	canyon brown	--77									
<b>Roof colour</b>											
	pastel white	-R1-									

The pastel white roof finish is standard on the L models and available at extra cost on the ordinary Microbus models.

# colours that suit you best.

Exterior colours.

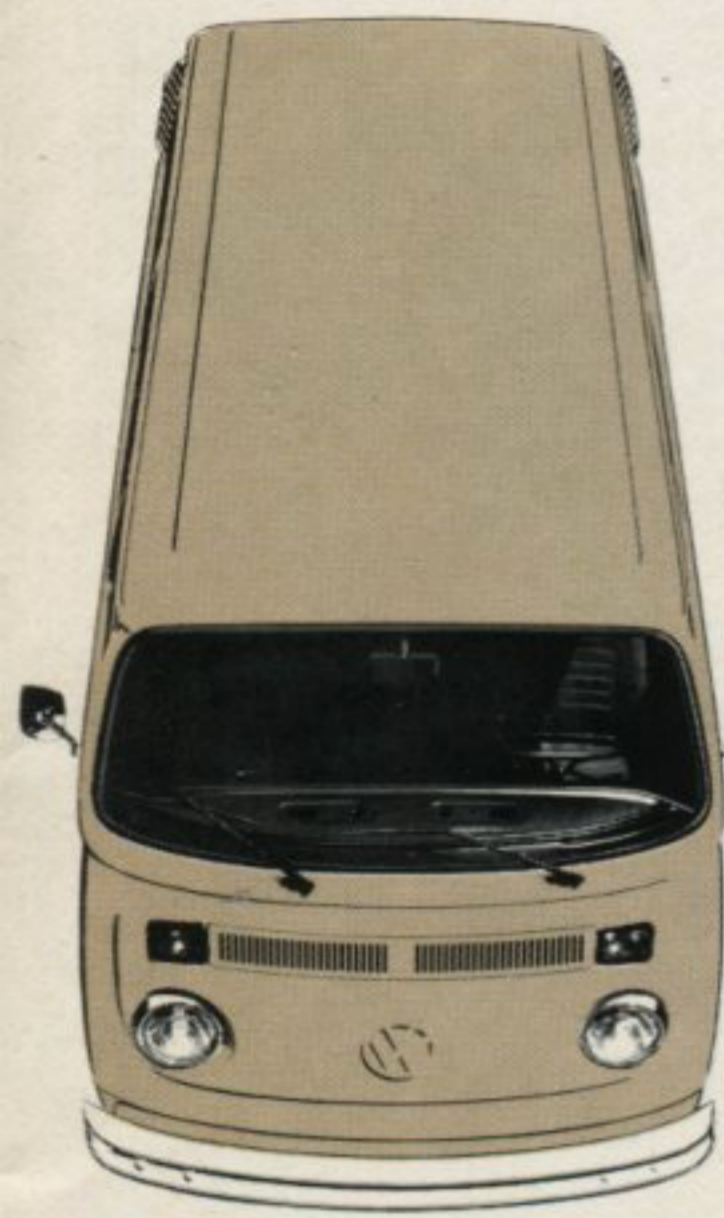

light grey

A7A7 -



marino yellow

E6E6 -



senegal red

G9G9 -

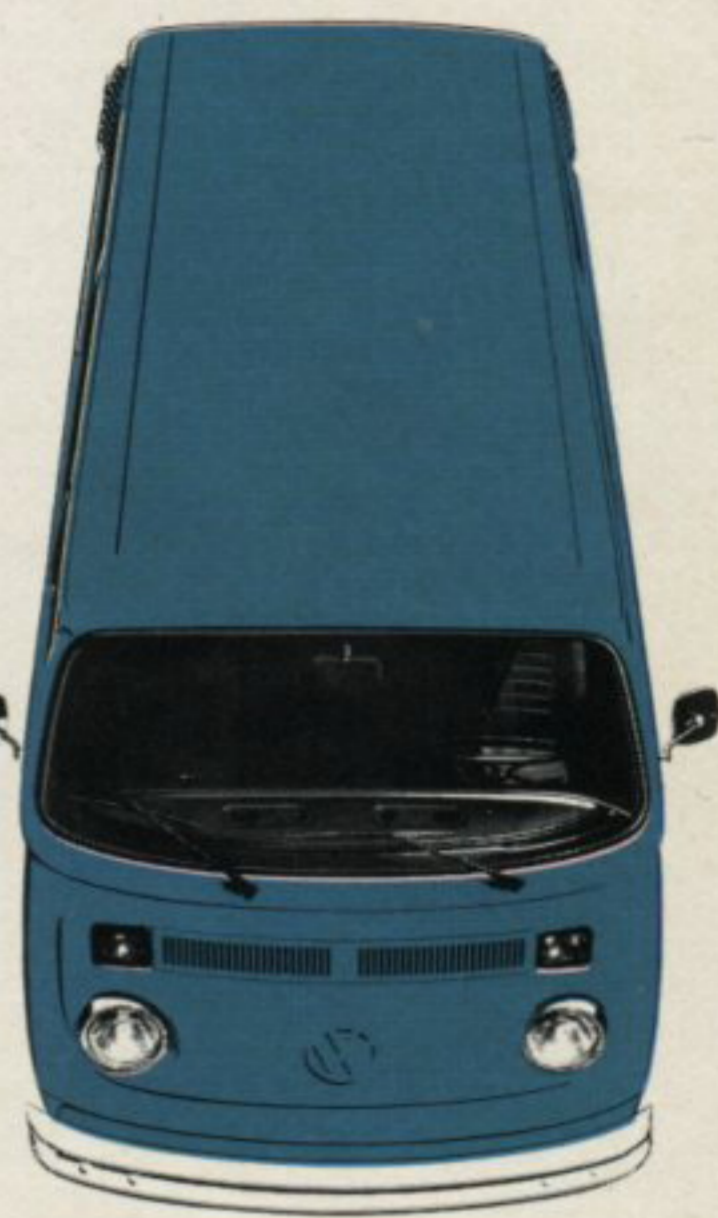

ocean blue

J4J4 -



neptune blue

J6J6 -



taiga green

P4P4 -

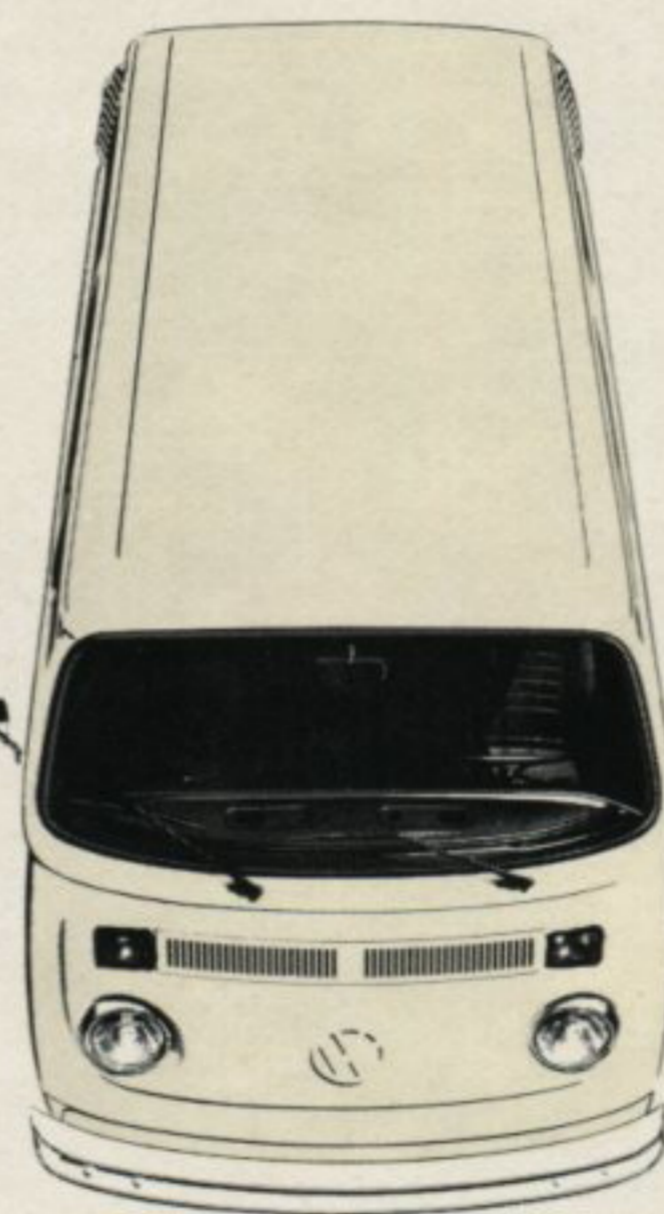

pastel white

R1R1 -

Print processes do not allow exact reproduction of colours. This applies to the exterior colours as well as to the upholstery.

# Ask for a test drive.

Volkswagens are delivered to 140 countries in the world over. Obviously, traffic laws and type-approval regulations tend to vary from country to country. You may find, therefore, that the models and equipment actually offered for sale differ from the data given in this brochure. So please ask your nearest VW dealer for information regarding the range of VW models and equipment valid for your country.